



Vogt Valves

Vogt Valves

*The Connection Bulletin for
Extended Body Forged Steel Valves
Welded Bonnet, Bolted Bonnet, Class 800 & Class 1500*

CB 22

Extended Body Forged Steel Valves



**EXTENDED BODY GATE & GLOBE VALVES
WELDED BONNET AND BOLTED BONNET
CLASS 800
CLASS 1500**

An extended body gate valve specifically designed for pressure measurement, venting, draining and sampling applications.

The extended end concept has an inherently greater length-strength ratio than the traditional "valve with nipple" welded assembly. It accommodates varying insulation thickness.

This is a ready to install outlet which provides reliable performance as well as significant savings in installation, inspection and maintenance time.

- Forged Steel Gate Valves Conform to API-602

An Extended Body Globe Valve Also Available.

Forged Steel Seal Weld Bonnet Gate Valves for Extended Body Valve Applications

Vogt Valves

Order by Size and Series Number

CONFORMS TO API-602

Dimensions are in inches.

- Outside screw & yoke
- Bolted gland
- Seal weld bonnet
- Solid wedge
- HF seats

Class 800 Conventional Port

100° F Ratings for Valves
Carbon Steel 1975 psi
Type 316 1920 psi

For other ratings see page 9

SERIES NUMBER	MATERIAL		TYPE ENDS	ILLUSTRATION (See page 3 for dimensions)
	Body/Bonnet	Trim		
TT 2801 Δ	Carbon Steel A105	13% Cr. ★	Integral Male Threaded Female Threaded	
TT 2831 Δ	316	316	Integral Male Threaded Female Threaded	
TT 2811 ◆ Δ (Inside Screw Stem)	Carbon Steel A105	13% Cr. ★	Integral Male Threaded Female Threaded	
ST 2801	Carbon Steel A105	13% Cr. ★	Integral Male Socket Weld Female Threaded	
SS 2801	Carbon Steel A105	13% Cr. ★	Female Socket Weld (not illustrated)	
ST 2831	316	316 ★	Integral Male Socket Weld Female Threaded	
CT 2801	Carbon Steel A105	13% Cr. ★	Integral Male Couplet Female Threaded	
CT 2831	316	316	Integral Male Couplet Female Threaded	
CT 2901	Carbon Steel A105	13% Cr. ★	Integrally Reinforced Extended Length Male Couplet Female Threaded	
CS 2901	Carbon Steel A105	13% Cr. ★	Female Socket Weld (not illustrated)	
CT 2911 ◆ (Inside Screw Stem)	Carbon Steel A105	13% Cr. ★	Integrally Reinforced Extended Length Male Couplet Female Socket Weld	
BT 2901	A105	13% Cr. ★	Integrally Reinforced Extended Length Butt Weld End Female Threaded	

Carbon Steel material conforms to ASTM A105. Stainless Steel material conforms to ASTM A182-F316.

◆ Inside Screw Stem valves are not illustrated; however, OS&Y dimensions shown are applicable, except for the open/closed dimensions.

† Normally furnished to these lengths. Other lengths can be fabricated - see page 9.

Δ 1/2" TT 2801, TT 2811 and TT 2831 valves are not covered under API-602 Rules.

★ Seats are hard faced.

Forged Steel Seal Weld Bonnet Gate Valves for Extended Body Valve Applications

CONFORMS TO API-602

Dimensions are in inches.

Order by Size and Series Number

		Class 800 Conventional Port Seal Weld Bonnet				100° F Ratings for Valves Carbon Steel 1975 psi Type 316 1920 psi		For other ratings see page 9								
Dimensions																
Valve Size	Weight in Pounds	A	B	C	D Max.	E	F Open	G Closed	H Handwheel Dia.	J	K	L	M	N	P	R
1/2	4.2	4.00	1.69	7.00	.47	.50	6.50	5.88	4.00	.64	.75	.84	1.25	.81	1.56	.97
3/4	4.2	4.00	1.69	7.00	.47	.50	6.50	5.88	4.00	.65	.75	1.05	1.25	.81	1.56	.97
1	7.4	4.38	2.00	7.50	.69	.75	8.31	7.38	4.75	.90	1.00	1.32	1.56	1.06	1.94	1.22
1 1/2	13.4	5.00	2.38	8.00	1.25	1.25	10.12	8.69	5.75	1.47	1.50	1.90	2.25	1.69	2.56	1.72

Order by Size and Series Number

Dimensions are in inches.

		Class 1500 Conventional Port Seal Weld Bonnet		100° F Ratings for Valves Carbon Steel 3705 psi						
SERIES NUMBER	MATERIAL		TYPE ENDS	ILLUSTRATION						
	Body/Bonnet	Trim								
ST 15801	Carbon Steel A105	13% Cr. ★	Integral Male Socket Weld Female Threaded							
Dimensions										
Valve	A	B	D	F Open	G Closed	H Handwheel Dia.	J	L	M	
1/2	4.69	2.00	.50	7.53	6.88	4.75	.69	.84	1.56	
3/4	4.69	2.00	.50	7.53	6.88	4.75	.75	1.05	1.56	
1	5.38	2.38	.75	9.69	8.78	7.00	1.12	1.32	2.25	

★ Seat is hard faced.

Forged Steel Bolted Bonnet Gate Valves for Extended Body Valve Applications

CONFORMS TO API-602

Dimensions are in inches.

Order by Size and Series Number

- Outside screw & yoke
- Bolted gland
- Bolted bonnet
- Solid wedge
- HF seats

SERIES NUMBER		MATERIAL		TYPE ENDS	ILLUSTRATION See page 6 for dimensions.
		Body/Bonnet	Trim		
Class 800 Conventional Port				100° F Ratings for Valves Carbon Steel 1975 psi	For other ratings see page 9
TT 12111	Carbon Steel A105	13% Cr. ★	Male Threaded Female Threaded		
ST 12111	Carbon Steel A105	13% Cr. ★	Male Socket Weld Female Threaded		
CT 12111	Carbon Steel A105	13% Cr. ★	Integrally Reinforced Extended Length Male Couplet Female Threaded		
CS 12111	Carbon Steel A105	13% Cr. ★	Female Socket Weld (not illustrated)		
BT 12111	Carbon Steel A105	13% Cr. ★	Integrally Reinforced Extended Length Butt Weld End Female Threaded		
BS 12111	Carbon Steel A105	13% Cr. ★	Female Socket Weld (not illustrated)		

★ Seats are hard faced.

Can be disassembled for post weld heat treat procedure only if gate orientation is marked and maintained when reassembled. Note: Series CT12111 valves do not require an interfacing fitting. The valve can be welded directly to the pipe header or vessel as illustrated for CT2901, page 8.

† Normally furnished to these lengths. Other lengths can be fabricated - see page 9.

Δ 1/2" - TT 12111 valves are not covered by API-602 rules.



Forged Steel Bolted Bonnet Gate Valves for Extended Body Valve Applications

Vogt Valves

Order by Size and Series Number

CONFORMS TO API-602

Dimensions are in inches.

Class 800 Conventional Port		100° F Ratings for Valves Carbon Steel 1975 psi		For other ratings see page 9											
Dimensions															
Valve Size	Weight in Pounds	A	B	C Max.	D Max.	E	F Open	G Closed	H Handwheel Dia.	J Max. Dia.	K	L	M	P	R
1/2	6.0	4.50	1.97	7.00	.47	.50	6.38	5.75	4.00	.64	.75	.84	1.56	1.56	.97
3/4	5.6	4.50	1.97	7.00	.50	.50	6.38	5.75	4.00	.75	.75	1.05	1.56	1.56	.97
1	9.4	5.25	2.09	7.50	.75	.75	8.31	7.38	4.75	1.00	1.00	1.32	1.94	1.94	1.22
1 1/2	13.4	6.00	2.72	8.00	1.25	1.25	10.12	8.69	5.75	1.50	1.50	1.90	2.56	2.56	1.72

★ Seats are hard faced.

Can be disassembled for post weld heat treat procedure if gate orientation is marked and maintained when reassembled. Note: Series CT12111 valves do not require an interfacing fitting. The valve can be welded directly to the pipe header or vessel as illustrated for CT2901, page 8.

† Normally furnished to these lengths. Other lengths can be fabricated - see page 9.

Forged Steel Bolted Bonnet Globe Valves for Extended Body Valve Applications

REPAIR IN-LINE

For in-line repair, this valve can be restored to first class service by lapping of the seat/disc, and can be disassembled before post weld heat treatment.

- Round bolted bonnet
- Spiral wound gasket
- Outside screw & yoke
- Bolted gland
- HF seat
- ASME B16.34

THROTTLING

Lower Cv factors permit throttling. May be used for pressure snubbing applications (pressure gauges, etc.)

Order by Size and Series Number

Dimensions are in inches.

SERIES NUMBER		MATERIAL		TYPE ENDS	ILLUSTRATION									
		Body/Bonnet	Trim											
CT 12141		Carbon Steel A105	13% Cr. ★	Integrally Reinforced Extended Length Male Couplet Female Threaded										
ST 12141		Carbon Steel A105	13% Cr. ★	Extended End Male Socket Weld Female Threaded										
TT 12141		Carbon Steel A105	13% Cr. ★	Extended End Male Threaded Female Threaded										
Dimensions														
Valve	A	B	C	G	H Open	J Closed	K Handwheel Dia.	L	M	N	P	R	S	T
1/2	7.00	2.00	.75	.50	6.62	6.19	4.00	.97	1.56	.84	.52	.31	4.50	1.44
3/4	7.00	2.00	.75	.50	6.62	6.19	4.00	.97	1.56	1.05	.65	.44	4.50	1.44
1	5.75	2.31	1.00	.75	8.44	7.81	4.75	1.22	1.94	1.32	.81	.44	5.25	1.75
1 1/2	6.50	3.12	1.47	1.28	10.38	9.47	5.75	1.72	2.56	1.90	1.47	.44	6.00	2.38
2	6.50	3.88	2.00	1.53	11.06	10.0	8.00	2.22	3.12	2.38	1.81	.56	6.00	2.94

★ Body seat is hard faced.
 Note: Series CT12141 valves do not require an interfacing fitting. The valve can be welded directly to the pipe header or vessel as illustrated for CT2901, page 8.
 † Normally furnished to these lengths. Other lengths can be fabricated - see page 9.

Insulation Capabilities

FLAT SURFACES

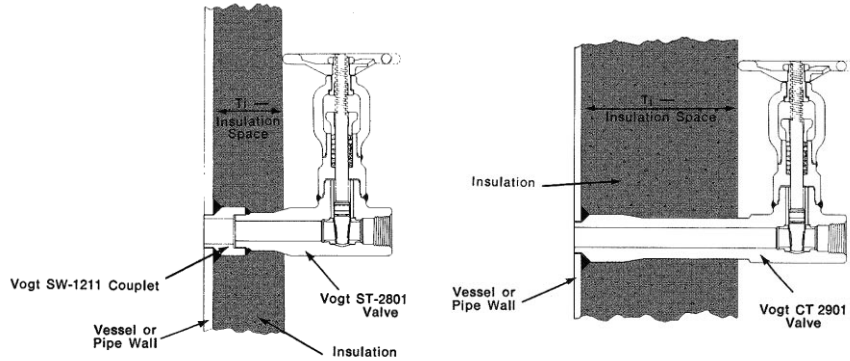

CURVED SURFACES

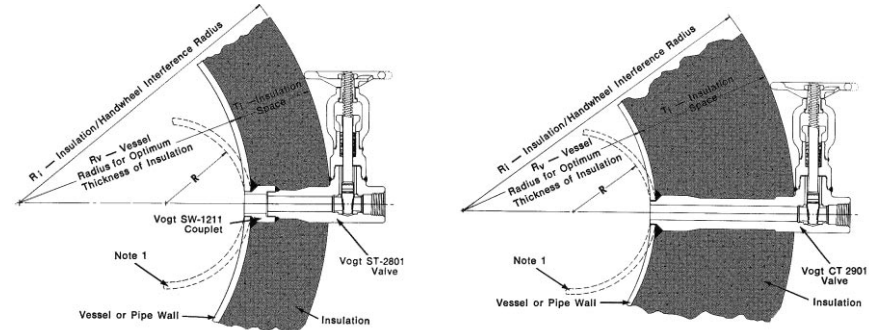

OPTIMUM INSULATION THICKNESS

SERIES NUMBER	FLAT SURFACES		CURVED SURFACES			
	Valve Size	Ti Max Insulation Space	Valve Size	Ri Inches	Ti Max Insulation Space	Rv
TT 2801 TT 2811** TT 2831	1/2	2.40	1/2	12.7	3.62	9.08
	3/4	2.45	3/4	12.7	3.66	9.04
	1	2.66	1	17.5	4.06	13.44
	1 1/2	3.06	1 1/2	21.9	4.65	17.25
ST 2801 ST 2831 SS 2801	1/2	2.63	1/2	12.7	3.84	8.86
	3/4	2.56	3/4	12.7	3.78	8.92
	1	2.87	1	17.5	4.28	13.22
	1 1/2	3.31	1 1/2	21.9	4.90	17.00
CT 2801* CT 2831*	1/2	2.00	1/2	12.7	3.22	9.48
	3/4	2.00	3/4	12.7	3.22	9.48
	1	2.00	1	17.5	3.41	14.09
	1 1/2	2.12	1 1/2	21.9	3.72	18.18
CT 2901 CT 2911	1/2	4.87	1/2	12.7	6.10	6.60
	3/4	4.87	3/4	12.7	6.10	6.60
	1	5.00	1	17.5	6.41	11.09
	1 1/2	5.00	1 1/2	21.9	6.60	15.30

* Series Numbers CT 2801 and CT 2831 valves do not require interfacing fitting. Valves can be welded directly to the vessel as illustrated for CT 2901.

**The insulation space (Ti) for Series No. TT 2811 will exceed those shown in this table.

Note 1: For vessels with radius less than **Rv**, the insulation space (Ti) is increased. For vessels with radius greater than **Rv**, the insulation space (Ti) is decreased.

Forged Steel Gate & Globe Valves for Extended Body Applications

**CT-2901, CT12111, CT12141,
ST12141 & TT12141 Series...**
can be modified for special applications



Vogt's unique method of construction of the Series CT-2901, CT12111 & CT12141, permits design flexibility and allows extended body valves to be modified with special extended male end dimension (either shorter or longer) while retaining the integral reinforcement feature. Users with special insulation thickness or space limitation requirements may find this feature desirable.

PRESSURE TEMPERATURE RATINGS			
Service Temperature (°F)	Class 800		Class 1500
	(1) (2) (4) Carbon Steel A105	(1) (3) A182- F316/316L	Carbon Steel A105
-20 to 100	1975	1920	3705
200	1800	1655	3375
300	1750	1495	3280
400	1690	1370	3170
500	1595	1275	2995
600	1460	1205	2735
650	1430	1185	2685
700	1420	1160	2665
750	1345	1140	2520
800	1100	1125	2060
850	715	1115	1340
900	460	1105	860
950	275	1030	515
1000	140	935	260
1050	—	—	—

- (1) Ratings are in accordance with procedures in ASME B16.34-96 Standard cClass.
- (2) Permissible but not recommended for prolonged use above 800°F.
- (3) F316 stainless steel containing max. carbon of .035. Do not use above 1000°F.
- (4) Only killed steel shall be used above 850°F.



Vogt Valves

1511 Jefferson Street
Sulphur Springs, TX 75482

US Sales Offices

Phone: 903-885-3151
Fax: 903-439-3386

Toll-Free Telephone Service

1-800-225-6989

Visit Our Website

www.flowserve.com

After Hours Customer Service

1-800-543-3927

Flowserve Corporation has established industry leadership in the design and manufacture of its products. When properly selected, this Flowserve product is designed to perform its intended function safely during its useful life. However, the purchaser or user of Flowserve products should be aware that Flowserve products might be used in numerous applications under a wide variety of industrial service conditions. Although Flowserve can (and often does) provide general guidelines, it cannot provide specific data and warnings for all possible applications. The purchaser/user must therefore assume the ultimate responsibility for the proper sizing and selection, installation, operation, and maintenance of Flowserve products. The purchaser/user should read and understand the Installation Operation Maintenance (IOM) instructions included with the product, and train its employees and contractors in the safe use of Flowserve products in connection with the specific application.

While the information and specifications contained in this literature are believed to be accurate, they are supplied for informative purposes only and should not be considered certified or as a guarantee of satisfactory results by reliance thereon. Nothing contained herein is to be construed as a warranty or guarantee, express or implied, regarding any matter with respect to this product. Because Flowserve is continually improving and upgrading its product design, the specifications, dimensions and information contained herein are subject to change without notice. Should any question arise concerning these provisions, the purchaser/user should contact Flowserve Corporation at any one of its worldwide operations or offices.

For more information about Flowserve Corporation, contact www.flowserve.com or call USA 1-800-225-6989.

FLOWSERVE CORPORATION

FLOW CONTROL DIVISION

Vogt Valves

1511 Jefferson Street
Sulphur Springs, TX 75482
Phone: 903-885-3151
Facsimile: 903-439-3386